

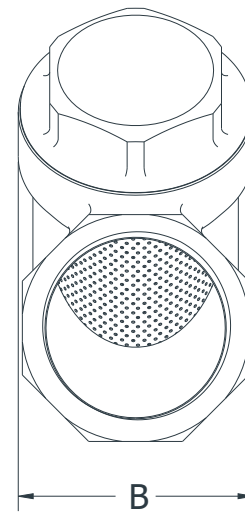

Y - STRAINER SCREWED END

FEATURES :

- FULL PORT, 1/2" ~ 2" (DN15 ~ DN50)
- WORKING PRESSURE : 580 PSI (PN40)
- WORKING TEMPERATURE : -20°C ~ 200°C (-4°F ~ 392°F)
- INVESTMENT CASTING
- THREAD TYPE : FEMALE THREADED ENDS ISO 228/1

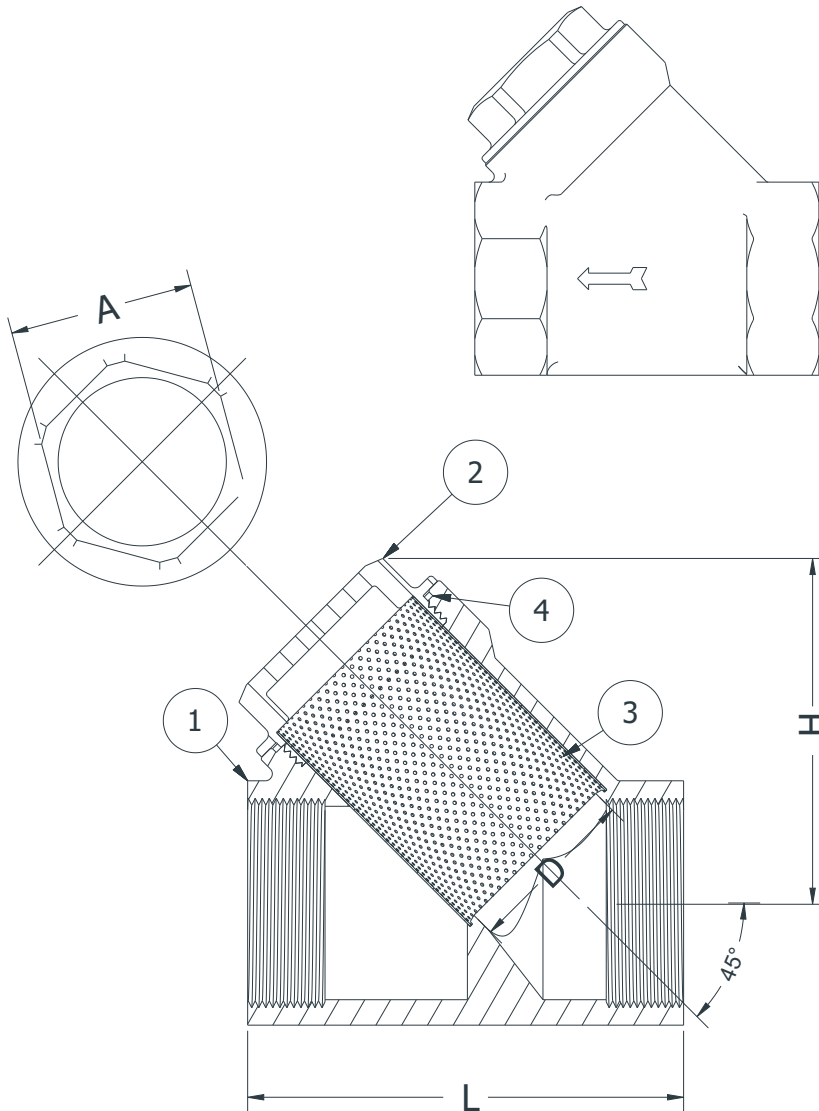

SPECIFICATION

Size	A	B	D	L	H	Weight
	(mm)	(mm)	(mm)	(mm)	(mm)	(Kg/Pcs)
1/2"	18.00	29.72	15.20	60.00	40.95	0,190
3/4"	24.10	34.70	20.56	74.00	48.68	0,289
1"	28.68	41.88	25.34	94.00	60.42	0,602
1 1/4"	37.00	49.28	31.50	100.00	73.45	0,744
1 1/2"	43.70	60.00	39.82	110.00	83.43	1,138
2"	52.76	71.22	49.30	124.00	96.70	1,642

No.	PART NAME	MATERIAL
1.	Body	ASTM A351 - CF8M
2.	Cap	ASTM A351 - CF8M
3.	Strainer	SS 304
4.	Seal	PTFE